

### Features

- AC'97 2.1 compliant codec
- 18-bit stereo full duplex  $\Sigma\Delta$  codec
- VSR (Variable Sampling Rate), 1Hz resolution
- 3D stereo expansion for simulated surround
- 4 stereo analog line-level inputs
- 2 mono analog line-level inputs
- MIC level input switchable from two sources
- Second line-level output with volume control
- Multiple codec mode
- External Audio Amplifier Control
- Power management support
- Low Power consumption mode
- Exceeds Microsoft® PC'9x requirements
- 3.3V, 5V or split analog/digital power supply
- 48-pin TQFP or LQFP package

### Description

IC Ensemble's ICE1232™ 18-bit  $\Sigma\Delta$  audio codec conforms to the AC'97 2.1 specification with excellent analog performance. The ICE1232 integrates a sophisticated Sample Rate Converter that can be adjusted in 1Hz increments. This makes it ideal for host-based signal processing motherboard applications which lacks a hardware accelerator. The mixer circuitry integrates a stereo enhancement to provide a pleasing 3D surround sound effect for stereo media. This codec is designed with aggressive power management to achieve ultra low power consumption when used with a 3.3V supply. The primary applications for this part are desktop and portable personal computers multimedia subsystems. However, it is suitable for any system requiring audio domain conversion, mixing and volume control at competitive prices.

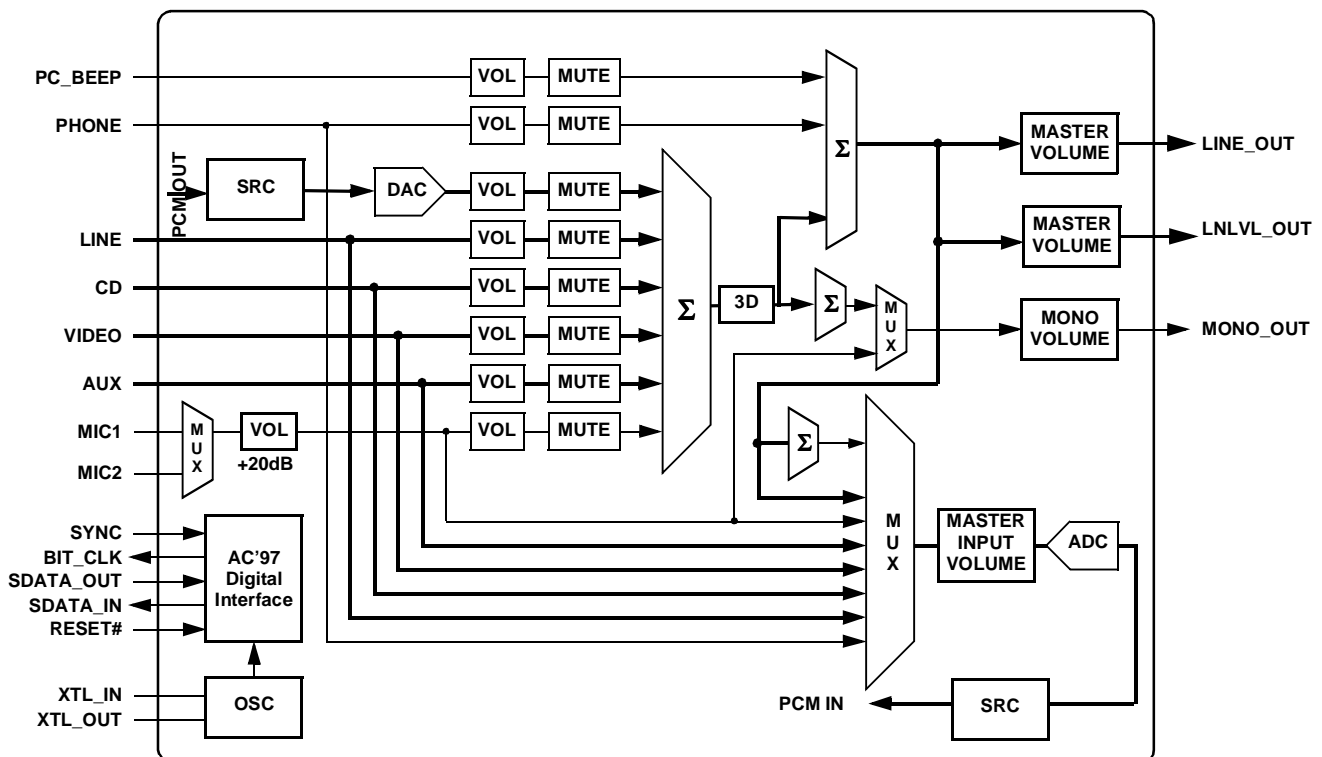

Figure 1. Functional Block Diagram

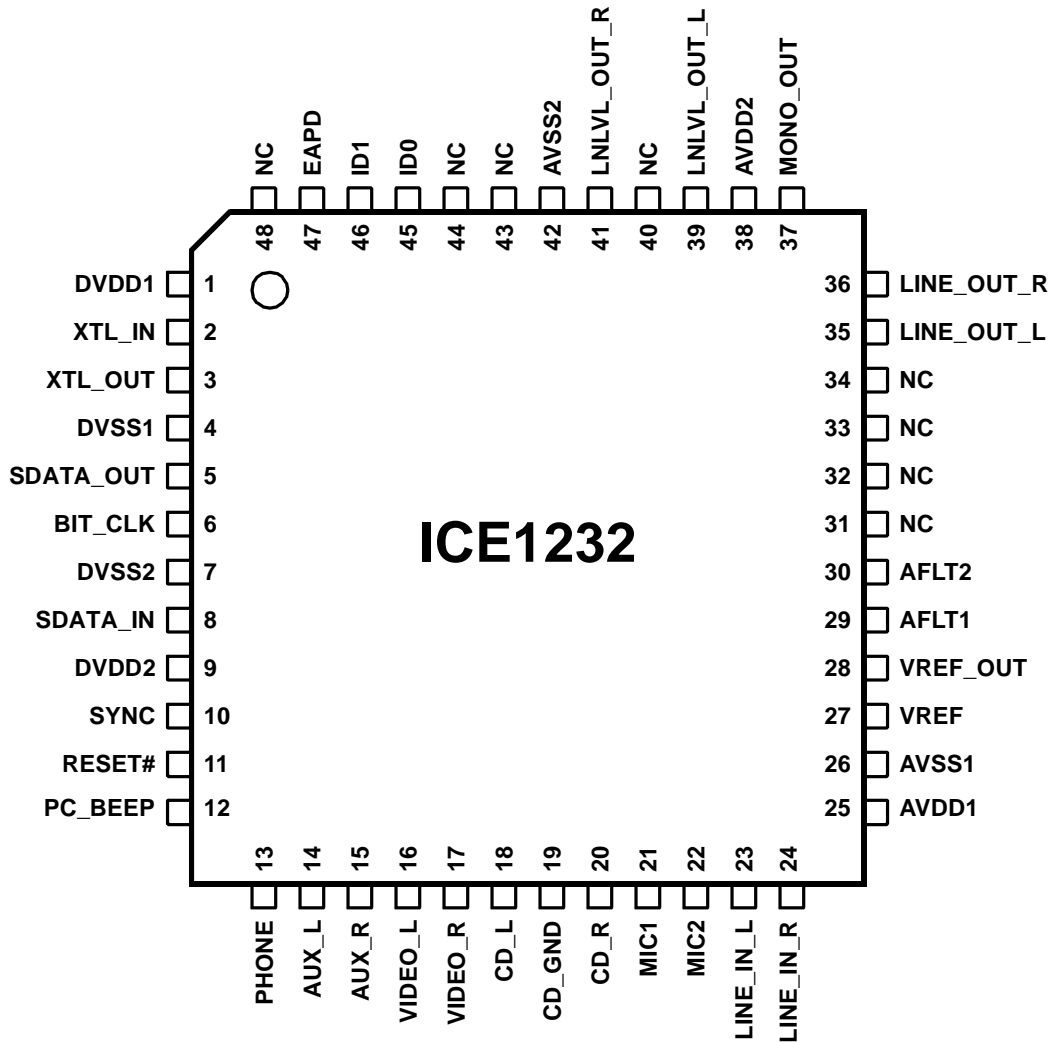

Figure 2. 48-pin TQFP/LQFP

© 1999-2000 IC Ensemble, Inc. All Rights Reserved.

IC ENSEMBLE PRODUCTS ARE NOT AUTHORIZED FOR, AND SHOULD NOT BE USED WITHIN, LIFE SUPPORT SYSTEMS OR NUCLEAR FACILITY APPLICATIONS WITHOUT THE SPECIFIC WRITTEN CONSENT OF IC ENSEMBLE, Inc. Life support systems are those intended to support or sustain life, and show failure to perform when used as directed can reasonably expect to result in personal injury or death. Nuclear facilities are those involved in the production, handling, use, storage, disposal, or any other activity involving fissionable materials or their waste products.

IC Ensemble, the IC Ensemble logo is a trademark of IC Ensemble, Inc. All other trademarks referenced in this document are owned by their respective companies.

IC Ensemble, Inc. believes the information contained herein to be correct at the time of the publication. The information is provided "AS IS" without warranty of any kind (expressed or implied). No responsibility is assumed by IC Ensemble, Inc. for the use of this information, nor infringements of patents or other rights of third parties. IC Ensemble, Inc. reserves the right to make changes at any time, without prior notice, to improve and supply the best possible product and is not responsible and does not assume any liability for misapplication or use outside the limits specified in this document. IC Ensemble provides no warranty for the use of its products and assumes no liability for errors contained in this document.

Table 1. Pin Description

Pin #	Symbol	Type	Description
1	DVDD1	P	Digital Supply Voltage, 5 or 3.3V. Match controller's Supply Voltage
2	XTL_IN	I	24.576MHz Crystal or clock input
3	XTL_OUT	O	24.576MHz Crystal
4	DVSS1	P	Digital Ground
5	SDATA_OUT	I	AC'97 Serial Data Input Stream
6	BIT_CLK	I/O	12.288MHz Serial Data Clock
7	DVSS2	P	Digital Ground
8	SDATA_IN	O	AC'97 Serial Data Output Stream
9	DVDD2	P	Digital Supply Voltage, 5 or 3.3V. Match controller's Supply Voltage
10	SYNC	I	48kHz Fixed Rate Sync Pulse
11	RESET#	I	AC'97 Master Reset
12	PC_BEEP	I	PC Speaker Beep Pass Through
13	PHONE	I	Telephony Subsystem Speakerphone
14	AUX_L	I	Auxiliary Audio Left Channel
15	AUX_R	I	Auxiliary Audio Right Channel
16	VIDEO_L	I	Video Audio Left Channel
17	VIDEO_R	I	Video Audio Right Channel
18	CD_L	I	CD Audio Left Channel
19	CD_GND	I	CD Audio Analog Ground
20	CD_R	I	CD Audio Right Channel
21	MIC1	I	Desktop Microphone
22	MIC2	I	Second Microphone
23	LINE_IN_L	I	Line In Left Channel
24	LINE_IN_R	I	Line In Right Channel
25	AVDD1	P	Analog Supply Voltage, 5V or 3.3V
26	AVSS1	P	Analog Ground
27	VREF	I	Reference Voltage
28	VREFOUT	O	Reference Voltage Output
29	AFLT1	O	Left Channel Anti-Aliasing Filter Capacitor
30	AFLT2	O	Right Channel Anti-Aliasing Filter Capacitor
31	NC	–	No Connect
32	NC	–	No Connect
33	NC	–	No Connect
34	NC	–	No Connect
35	LINE_OUT_L	O	Line Out Left Channel
36	LINE_OUT_R	O	Line Out Right Channel
37	MONO_OUT	O	Mono Output

Table 1. Pin Description (continued...)

Pin #	Symbol	Type	Description
38	AVDD2	P	Analog Supply Voltage, 5V or 3.3V
39	LNLVL_OUT_L	O	Alternate Left Line Level out
40	NC	–	No Connect
41	LNLVL_OUT_R	O	Alternate Right Line Level out
42	AVSS2	P	Analog Ground
43	NC	–	No Connect
44	NC	–	No Connect
45	ID0	I	Multiple Codec Select (Internal pull-up). <i>Please see Table 19.</i>
46	ID1	I	Multiple Codec Select (Internal pull-up). <i>Please see Table 19.</i>
47	EAPD	O	External Power Amplifier Power Down
48	NC	–	No Connect

**Note:** ICE1232 supports mixed +5V and +3.3V analog and digital power supply combinations. **You must use 3.3V as digital supply if the AC-link controller is also 3.3V.** For best analog performance use 5V analog supply. For maximum power savings use 3.3V for both analog and digital sections.

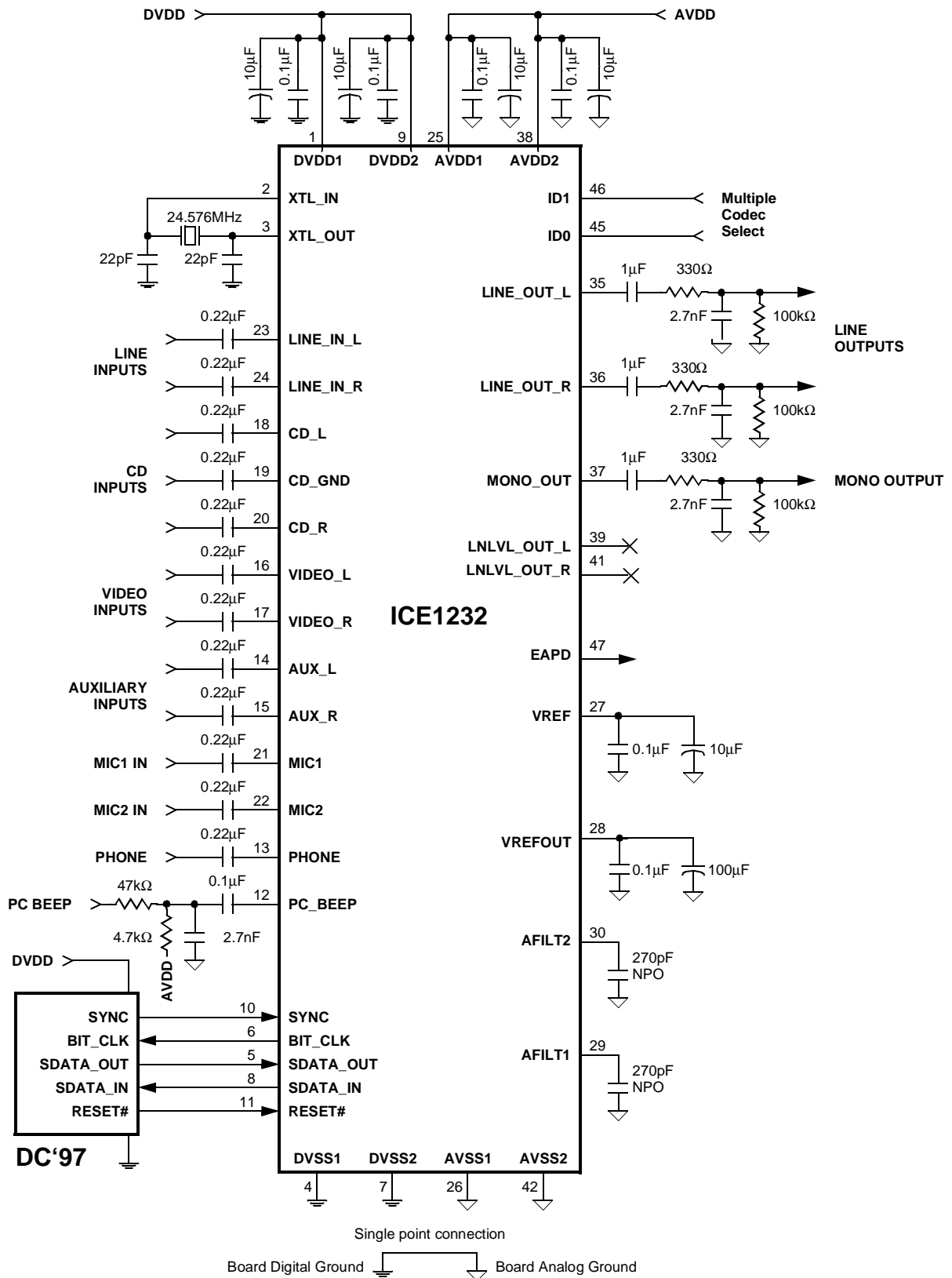

Figure 3. Typical Connection Diagram

## Absolute Maximum Ratings

**Table 2. Absolute Maximum Ratings**

( AVSS = DVSS = 0V)

Symbol	Parameter	Min	Typ	Max	Unit
–	Power Supplies (AVDD, DVDD)	-0.3		6.0	V
–	Input Current per Pin	-10		10	mA
–	Output Current per Pin	-15		15	mA
–	Digital Input Voltage	-0.3		DVDD+0.3	V
–	Analog Input Voltage	-0.3		AVDD+0.3	V
–	Total Power Dissipation			TBD	W
–	Ambient Temperature	-55		110	°C
–	Storage Temperature	-65		150	°C

**Caution:** Exceeding any of these limits can cause permanent failure of the device and will void any claims against product quality.

## Recommended Operating Conditions

**Table 3. Recommended Operating Conditions**

( AVSS = DVSS = 0V)

Symbol	Parameter	Min	Typ	Max	Unit
–	Digital Power Supplies (DVDD), preferred	3.135	3.3	3.465	V
–	Digital Power Supplies (DVDD), if controller 5V	4.75	5	5.25	V
–	Analog Power Supplies (AVDD), preferred	4.75	5	5.25	V
–	Analog Power Supplies (AVDD), for low power apps	3.135	3.3	3.465	V
–	Operating Ambient Temperature	0		70	°C

## Performance Specifications

Table 4. Analog Performance Characteristics (+5V Power)

TA=25°C, AVDD = DVDD = 5.0V ± 5%; AVSS = DVSS = 0V; 10kΩ / 50pF Load; Fs = 48kHz, 0dB = 1VRMS; BW: 20Hz ~ 20kHz, 0dB Attenuation, IB[1:0]=00 (power up default), as measured on a 2-layers AMR eval card

Symbol	Parameter	Min	Typ	Max	Unit
	Full Scale Input Voltage: Line Inputs		1.0		VRMS
	Mic Inputs (20dB = 0)		1.0		VRMS
	Mic Inputs (20dB = 1)		0.1		VRMS
	Full Scale Output Voltage: Line Outputs		1.0		VRMS
	Mono Output		1.0		VRMS
	Analog S/N: CD to LINE_OUT		95		dB
	Other to LINE_OUT		95		dB
	Analog Frequency Response	20		20,000	Hz
	Digital S/N: DAC	85	94		dB
	ADC	75	90		dB
	Total Harmonic Distortion: LINE_IN to LINE_OUT		-88	-74	dB
	(DA) DAC to LINE_OUT		-86	-74	dB
	D/A and A/D Frequency Response: DAC	20		19,200	Hz
	ADC	20		19,200	Hz
	Transition Band: DAC	19,200		28,800	Hz
	ADC	19,200		28,800	Hz
	Stop Band: DAC	28,800		infinity	Hz
	ADC	28,800		infinity	Hz
	Stop Band Rejection: DAC	75			dB
	ADC	75			dB
	Out-of-Band Rejection		-40		dB
	Group Delay			1	ms
	Power Supply Rejection Ratio (1kHz)		-40		dB
	Input Channel Crosstalk			-70	dB
	Spurious Tone Reduction		-100		dB
	Attenuation, Gain Step Size		1.5		dB
	Input Impedance	10	45		kΩ
	Input Capacitance		15		pF
	VREFOUT	2.0	2.4	2.8	V

**Note:** VIL = 0.8V, VIH = 2.0V

Analog Frequency Response has ±1dB limits

SNR (measured as THD+N) of rms output level with 1kHz full-scale input to rms output level with all zeros into digital input

Measured "A wtd" over a 20Hz ~ 20kHz bandwidth (AES17-1991 Idle Channel Noise or EIAJ CP-307 SNR)

THD: 0dB gain, 20kHz BW, Fs = 48kHz, -3dB "large" signal

A/D and D/A Frequency Response has ±0.25dB limits

Stop Band Rejection determines filter requirements

Out-of-Band rejection determines audible noise

Integrated Out-of-band noise generated by DAC during normal PCM audio playback over: BW = 28.8kHz~100kHz, with respect to 1 VRMS DAC output

Performance Specifications (continued...)

**Table 5. Analog Performance Characteristics (+3.3V Power)**

TA=25°C, AVDD = DVDD = 3.3V ± 5%; AVSS = DVSS = 0V; 10kΩ / 50pF Load; Fs = 48kHz, 0dB = 0.70VRMS;  
 BW: 20Hz ~ 20kHz, 0dB Attenuation, IB[1:0]=10 (set by software), as measured on a 2-layers PCI add-in card

Symbol	Parameter	Min	Typ	Max	Unit
	Full Scale Input Voltage: Line Inputs		0.7		VRMS
	Mic Inputs (20dB = 0)		0.7		VRMS
	Mic Inputs (20dB = 1)		0.07		VRMS
	Full Scale Output Voltage: Line Outputs		0.70		VRMS
	Mono Output		0.07		VRMS
	Analog S/N: CD to LINE_OUT		92		dB
	Other to LINE_OUT		92		dB
	Analog Frequency Response	20		20,000	Hz
	Digital S/N: DAC		90		dB
	ADC		85		dB
	Total Harmonic Distortion: Line Outputs		-70		dB
	D/A and A/D Frequency Response: DAC	20		19,200	Hz
	ADC	20		19,200	Hz
	Transition Band: DAC	19,200		28,800	Hz
	ADC	19,200		28,800	Hz
	Stop Band: DAC	28,800		infinity	Hz
	ADC	28,800		infinity	Hz
	Stop Band Rejection: DAC	TBD			dB
	ADC	TBD			dB
	Out-of-Band Rejection		-40		dB
	Group Delay			1	ms
	Power Supply Rejection Ration (1kHz)		-40		dB
	Input Channel Crosstalk			-70	dB
	Spurious Tone Reduction		-100		dB
	Attenuation, Gain Step Size		1.5		dB
	Input Impedance	10	50		kΩ
	Input Capacitance		15		pF
	VREFOUT		1.5		V

**Note:** VIL = 0.6V, VIH = 1.6V

Analog Frequency Response has ±1dB limits

SNR (measured as THD+N) of rms output level with 1kHz full-scale input to rms output level with all zeros into digital input

Measured “A wtd” over a 20Hz ~ 20kHz bandwidth (AES17-1991 Idle Channel Noise or EIAJ CP-307 SNR)

THD: 0dB gain, 20kHz BW, Fs = 48kHz, -3dB “large” signal

A/D and D/A Frequency Response has ±0.25dB limits

Stop Band Rejection determines filter requirements

Out-of-Band rejection determines audible noise

Integrated Out-of-band noise generated by DAC during normal PCM audio playback over: BW = 28.8kHz~100kHz, with respect to 0.70 VRMS DAC output



## Performance Specifications (continued...)

**Table 6. Miscellaneous Analog Performance Characteristics**

( $T_A=25^\circ\text{C}$ ,  $AVDD = DVDD = 5.0\text{V} \pm 5\%$ ;  $AVSS = DVSS = 0\text{V}$ ;  $10\text{k}\Omega / 50\text{pF}$  Load);  $F_s = 48\text{kHz}$ ,  $0\text{dB} = 1\text{VRMS}$ ;  
 BW:  $20\text{Hz} \sim 20\text{kHz}$ ,  $0\text{dB}$  Attenuation)

Symbol	Parameter	Min	Typ	Max	Unit
	Mixer Gain Range Span: LINE_IN, AUX, VIDEO, MIC1, MIC2, PHONE, PC_BEEP LINE_OUT, MONO_OUT		46.5 46.5		dB dB
	Mixer Step Size: All Volume Controls except PC_BEEP PC_BEEP		1.5 3.0		dB dB
	Mixer Mute Level		110		dB
	Mixer Gain: Interchannel Gain Mismatch Gain Drift	-0.5	100	0.5	dB ppm/ $^\circ\text{C}$
	ADC and Analog Inputs ( $R_s=50\Omega$ ): Resolution Gain Error Offset Error Input Impedance		$\pm 2$ 10 50	18 $\pm 5$	bits % mV k $\Omega$
	DAC and Analog Outputs: Resolution Interchannel Isolation Interchannel Gain Mismatch Gain Error Gain Drift		80 0.1 60	18 0.2 $\pm 5$	bits dB dB % ppm/ $^\circ\text{C}$

## Electrical Specifications

**Table 7. DC Characteristics**

( $T_A=25^\circ\text{C}$ ,  $AVDD = DVDD = 5.0\text{V}$  or  $3.3\text{V} \pm 5\%$ ;  $AVSS = DVSS = 0\text{V}$ ;  $50\text{pF}$  Load )

Symbol	Parameter	Min	Typ	Max	Unit
$V_{IN}$	Input Voltage Range	-0.3		$V_{DD}+0.3$	V
$V_{IL}$	Input Low Voltage			$0.2 \times V_{DD}$	V
$V_{IH}$	Input High Voltage	$0.4 \times V_{DD}$			V
$V_{OL}$	Output Low Voltage			$0.2 \times V_{DD}$	V
$V_{OH}$	Output High Voltage	$0.5 \times V_{DD}$			V
–	Input Leakage Current (AC-Link)	-10		10	$\mu\text{A}$
–	Output Leakage Current (AC-Link and Hi-Z)	-10		10	$\mu\text{A}$
–	Output Buffer Drive Current		TBD		mA

**Electrical Specifications (continued...)**

**Table 8. Power Consumption (+5V Power)**

( TA=25°C, AVDD = DVDD = 5.0V ± 5%; AVSS = DVSS =0V; 50pF Load )

Symbol	Parameter	Min	Typ	Max	Unit
IVDD	Digital Supply Current: Power Up		58		mA
IVDD	Digital Supply Current: Power Down		0.2		mA
IAVDD	Analog Supply Current: Power Up default		44		mA
IAVDD	Analog Supply Current: Power Up, IB[1:0]=11		17		mA
IAVDD	Analog Supply Current: Power Down, IB[1:0]=xx		0.4		mA

**Table 9. Power Consumption (+3.3V Power)**

( TA=25°C, AVDD = DVDD = 3.3V ± 5%; AVSS = DVSS =0V; 50pF Load )

Symbol	Parameter	Min	Typ	Max	Unit
IVDD	Digital Supply Current: Power Up		32		mA
IVDD	Digital Supply Current: Power Down		0.03		mA
IAVDD	Analog Supply Current: Power Up default		27		mA
IAVDD	Analog Supply Current: Power Up, IB[1:0]=11		11		mA
IAVDD	Analog Supply Current: Power Down, IB[1:0]=xx		0.25		mA

**AC Timing Characteristics**

(Test Conditions: TA=25°C, AVDD = DVDD = 5.0V or 3.3V ± 5%; AVSS = DVSS =0V; 50pF Load)

**Table 10. Cold Reset**

Symbol	Parameter	Min	Typ	Max	Unit
TRST_LOW	RESET# Active Low Pulse Width	1			µs
TRST2CLK	RESET# Inactive to BIT_CLK Startup Delay	162.8			ns

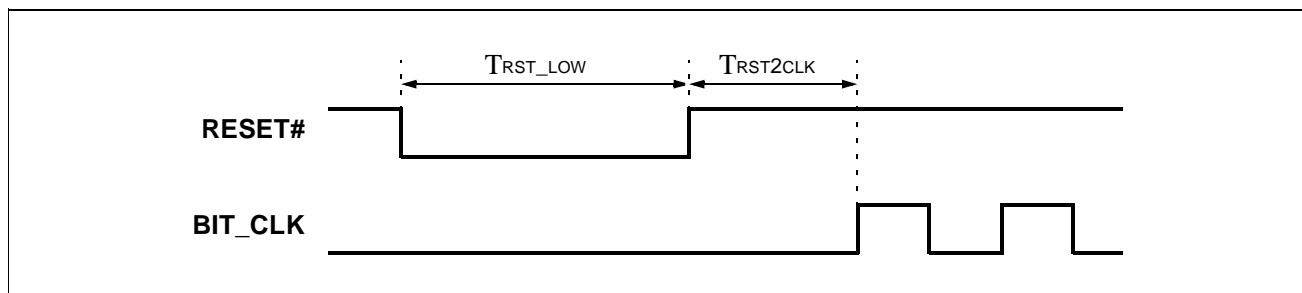

**Figure 4. Cold Reset Timing**

AC Timing Characteristics (continued...)

Table 11. Warm Reset

Symbol	Parameter	Min	Typ	Max	Unit
TSYNC_HIGH	Sync Active High Pulse Width		1.3		μs
TSYNC2CLK	SYNC Inactive to BIT_CLK Startup Delay	162.8			ns

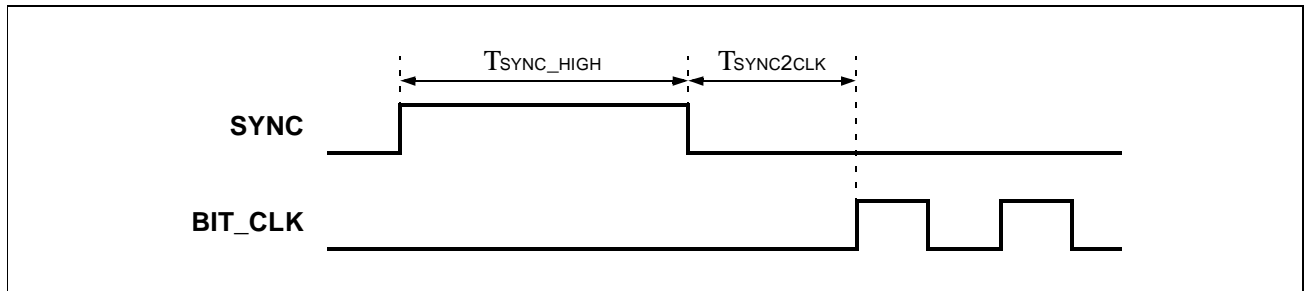

Figure 5. Warm Reset Timing

Table 12. BIT\_CLK / SYNC Timing

Symbol	Parameter	Min	Typ	Max	Unit
	BIT_CLK Frequency		12.288		MHz
TCLK_PERIOD	BIT_CLK Period		81.4		ns
	BIT_CLK Output Jitter			750	ps
TCLK_HIGH	BIT_CLK Pulse Width (high)	32.56	40.7	48.84	ns
TCLK_LOW	BIT_CLK Pulse Width (low)	32.56	40.7	48.84	ns
TCLK_DC	BIT_CLK Duty Cycle	40		60	%
	SYNC Frequency		48		kHz
TSYNC_PERIOD	SYNC Period		20.8		μs
TSYNC_HIGH	SYNC Pulse Width (high)		1.3		μs
TSYNC_LOW	SYNC Pulse Width (low)		19.5		μs

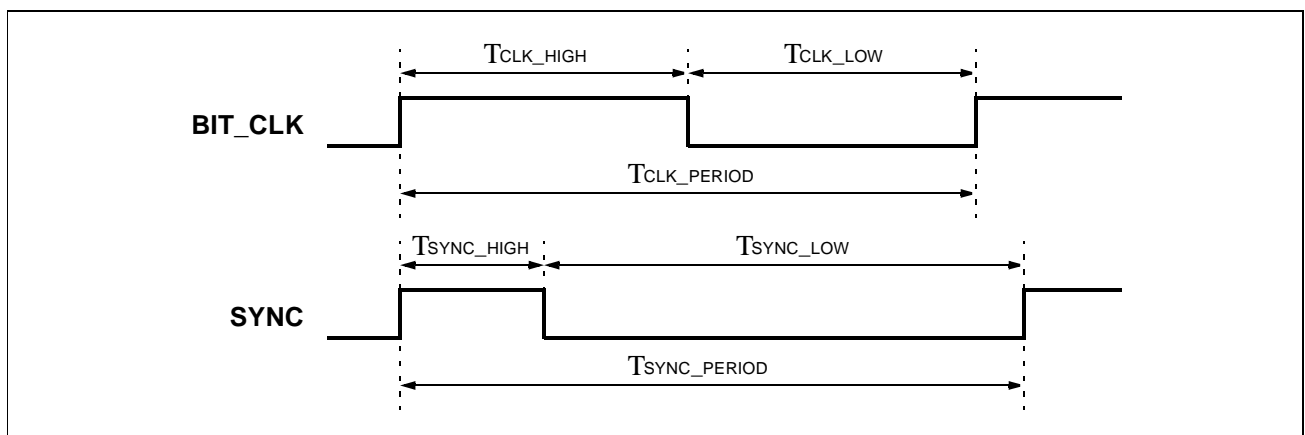

Figure 6. BIT\_CLK to SYNC Timing

AC Timing Characteristics (continued...)

Table 13. Setup and Hold

Symbol	Parameter	Min	Typ	Max	Unit
TSETUP1	SDATA_OUT Setup to falling edge of BIT_CLK	15			ns
THOLD1	SDATA_OUT Hold from falling edge of BIT_CLK	5			ns
TSETUP2	SYNC Setup to rising edge of BIT_CLK	15			ns
THOLD2	SYNC Hold to rising edge of BIT_CLK	5			ns

Note: SDATA\_IN seup and hold calculations determined by AC'97 controller propagation delay.

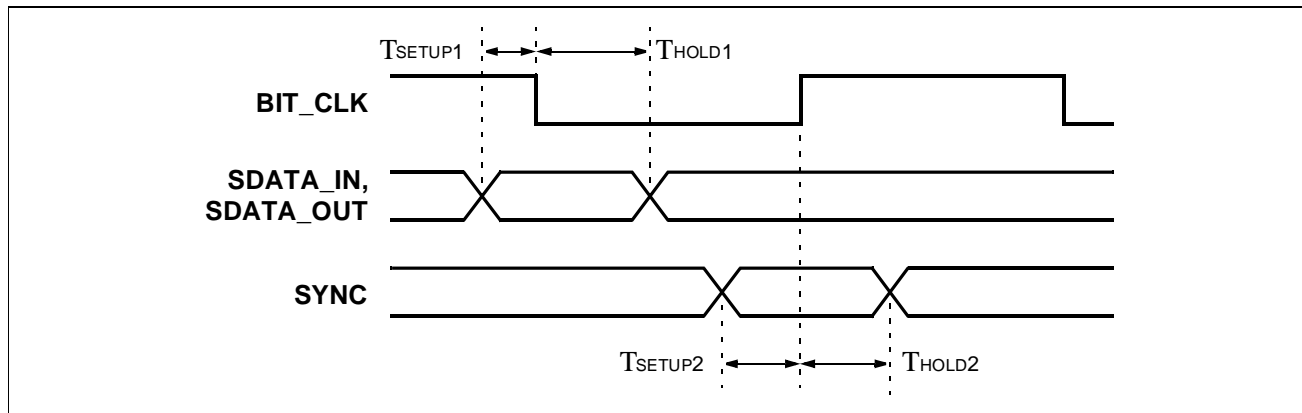

Figure 7. Setup and Hold Time

Table 14. Rise and Fall Time

Symbol	Parameter	Min	Typ	Max	Unit
TRISE	BIT_CLK rise time	2		6	ns
TFALL	BIT_CLK fall time	2		6	ns
TRISE	SYNC rise time	2		6	ns
TFALL	SYNC fall time	2		6	ns
TRISE	SDATA_IN rise time	2		6	ns
TFALL	SDATA_OUT fall time	2		6	ns
TRISE	SDATA_OUT rise time	2		6	ns
TFALL	SDATA_OUT fall time	2		6	ns

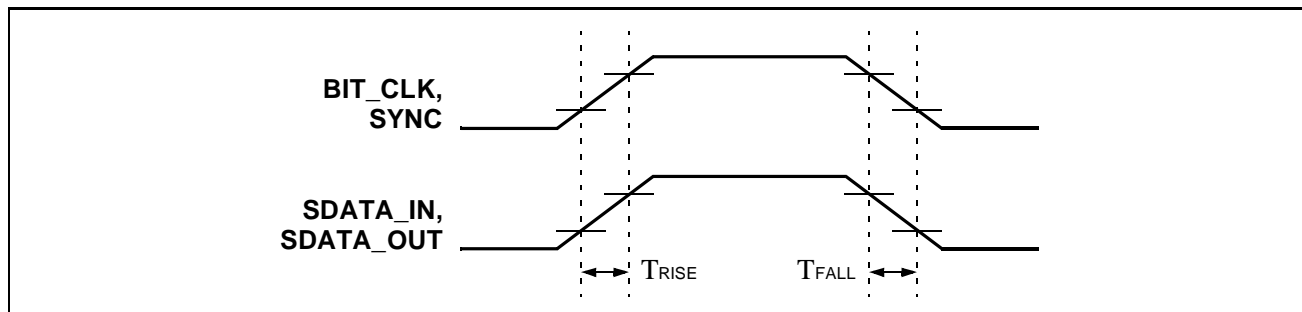

Figure 8. Rise Time and Fall Time

AC Timing Characteristics (continued...)

Table 15. AC Link Low Power Mode

Symbol	Parameter	Min	Typ	Max	Unit
TS2_PDOWN	End of Slot 2 to BIT_CLK / SDATA_IN low			1	μs

Note: BIT\_CLK not to scale.

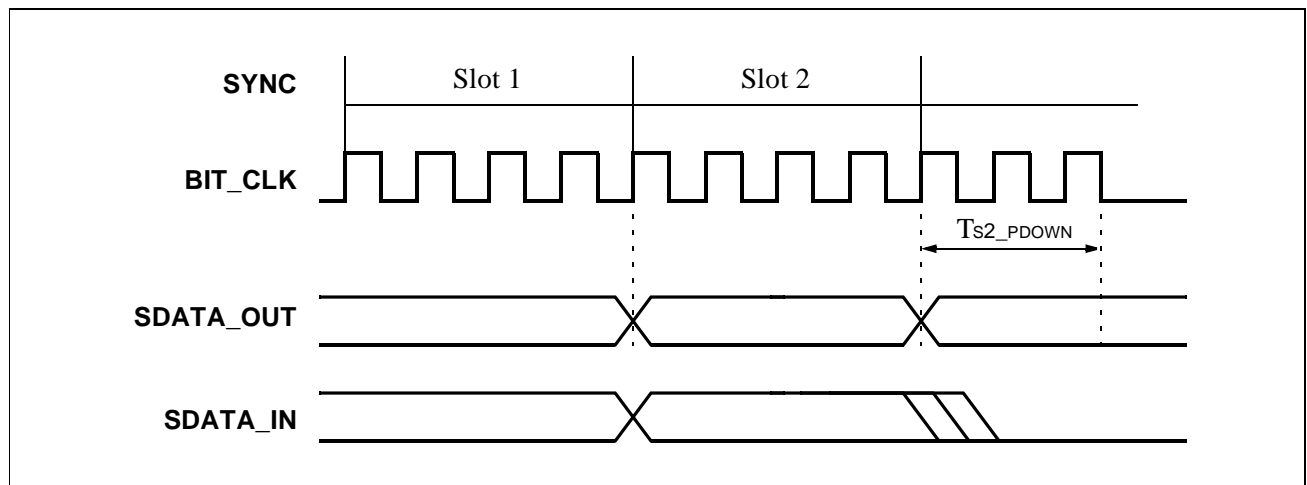

Figure 9. AC Link Power Mode Timing

Table 16. ATE/Vendor Test Mode

Symbol	Parameter	Min	Typ	Max	Unit
TSETUP2RST	SDATA_OUT/SYNC setup to RESET# rising edge	15			ns
TOFF	RESET# rising edge to Hi-Z state			25	ns

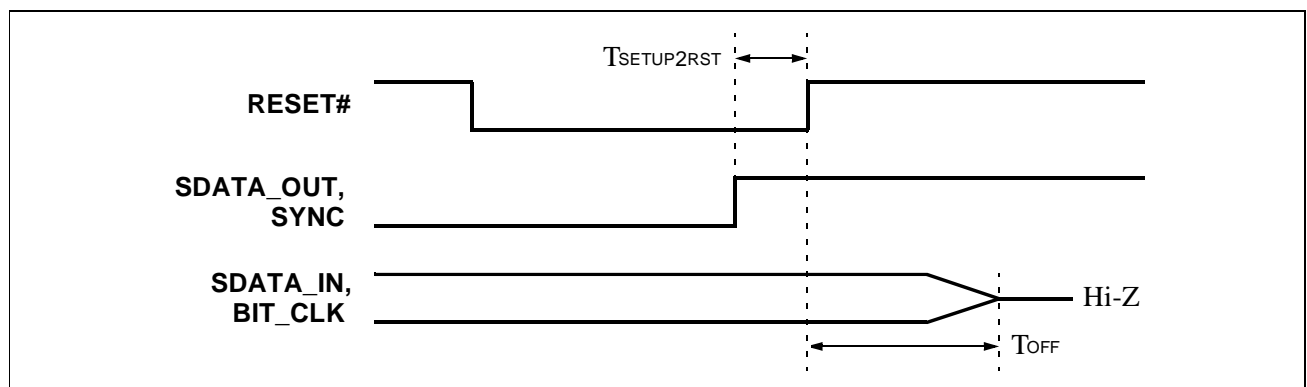

Figure 10. ATE/Vendor Test Mode Timing

Register Map

Index	Register Name	D15	D14	D13	D12	D11	D10	D9	D8	D7	D6	D5	D4	D3	D2	D1	D0
00h	Reset	–	SE4	SE3	SE2	SE1	SE0	ID9	ID8	ID7	ID6	ID5	ID4	ID3	ID2	ID1	ID0
02h	Stereo Output Volume	Mute	–	–	ML4	ML3	ML2	ML1	ML0	–	–	–	MR4	MR3	MR2	MR1	MR0
04h	Alt. Line Output Vol.	Mute	–	–	ML4	ML3	ML2	ML1	ML0	–	–	–	MR4	MR3	MR2	MR1	MR0
06h	Mono Output Volume	Mute	–	–	–	–	–	–	–	–	–	–	MM4	MM3	MM2	MM1	MM0
0Ah	PC Beep Volume	Mute	–	–	–	–	–	–	–	–	–	–	PV3	PV2	PV1	PV0	–
0Ch	Phone Volume	Mute	–	–	–	–	–	–	–	–	–	–	GN4	GN3	GN2	GN1	GN0
0Eh	Mic In Volume	Mute	–	–	–	–	–	–	–	–	20dB	–	GN4	GN3	GN2	GN1	GN0
10h	Line In Volume	Mute	–	–	GL4	GL3	GL2	GL1	GL0	–	–	–	GR4	GR3	GR2	GR1	GR0
12h	CD In Volume	Mute	–	–	GL4	GL3	GL2	GL1	GL0	–	–	–	GR4	GR3	GR2	GR1	GR0
14h	Video In Volume	Mute	–	–	GL4	GL3	GL2	GL1	GL0	–	–	–	GR4	GR3	GR2	GR1	GR0
16h	Aux In Volume	Mute	–	–	GL4	GL3	GL2	GL1	GL0	–	–	–	GR4	GR3	GR2	GR1	GR0
18h	PCM Out volume	Mute	–	–	GL4	GL3	GL2	GL1	GL0	–	–	–	GR4	GR3	GR2	GR1	GR0
1Ah	Record Select	–	–	–	–	–	SL2	SL1	SL0	–	–	–	–	–	SR2	SR1	SR0
1Ch	Record Gain	Mute	–	–	–	GL3	GL2	GL1	GL0	–	–	–	–	GR3	GR2	GR1	GR0
20h	General Purpose	–	–	3D	–	–	–	MIX	MS	LPBK	–	–	–	–	–	–	–
22h	3D Control	–	–	–	–	–	–	–	–	–	–	–	–	DP3	DP2	DP1	DP0
26h	Power Down & Status	EAPD	PR6	PR5	PR4	PR3	PR2	PR1	PR0	–	–	–	–	REF	ANL	DAC	ADC
28h	Extended Audio ID	ID1	ID0	–	–	–	–	AMAP	–	–	–	–	–	–	–	–	VRA
2Ah	Ext. Audio Stat/Control	–	–	–	–	–	–	–	–	–	–	–	–	–	–	–	VRA
2Ch	PCM Front DAC Rate	SR15	SR14	SR13	SR12	SR11	SR10	SR9	SR8	SR7	SR6	SR5	SR4	SR3	SR2	SR1	SR0
32h	PCM LR ADC Rate	SR15	SR14	SR13	SR12	SR11	SR10	SR9	SR8	SR7	SR6	SR5	SR4	SR3	SR2	SR1	SR0
...	...	...	...	...	...	...	...	...	...	...	...	...	...	...	...	...	...
5Ah	Test Control Register	–	–	–	–	–	–	–	–	Res.	Res.	Res.	Res.	IB1	IB0	–	Res.
...	...	...	...	...	...	...	...	...	...	...	...	...	...	...	...	...	...
7Ah	Vendor Reserved	–	–	–	–	–	–	–	–	–	–	–	–	–	–	–	–
7Ch	Vendor ID1	F7	F6	F5	F4	F3	F2	F1	F0	S7	S6	S5	S4	S3	S2	S1	S0
7Eh	Vendor ID2	T7	T6	T5	T4	T3	T2	T1	T0	REV7	REV6	REV5	REV4	REV3	REV2	REV1	REV0

In compliance with the AC '97 rev. 2.1 specification, all reserved or non-implemented register bits, non-implemented addresses, odd register addresses return 0 when read. Vendor specific registers 5Ah - 7Ah are reserved and should not be written for regular operation, unless otherwise specified.

## Register Description

### Reset Register (Index 00h)

D15	D14	D13	D12	D11	D10	D9	D8	D7	D6	D5	D4	D3	D2	D1	D0	Default
–	SE4	SE3	SE2	SE1	SE0	ID9	ID8	ID7	ID6	ID5	ID4	ID3	ID2	ID1	ID0	6D50h

The Reset register is used to configure the hardware to a known state or to read the ID code of the part. A code was assigned to IC Ensemble (27 = 11011h) for 3D Stereo Enhancement reflected in SE[4:0]. ID8 and ID6 are set to 1b to report that the ADC and DAC are 18-bit resolution respectively. The ICE1232 supports an alternate line level out with independent volume control as reflected by ID4=1b. Writing data to this register will set all the mixer registers to their default values. For description of the bits set to 0b, refer to AC'97 Rev. 2.1 spec.

### Stereo Output Control Register (Index 02h)

D15	D14	D13	D12	D11	D10	D9	D8	D7	D6	D5	D4	D3	D2	D1	D0	Default
Mute	–	–	ML4	ML3	ML2	ML1	ML0	–	–	–	MR4	MR3	MR2	MR1	MR0	8000h

#### Mute **Stereo Output Mute Control**

“1” : Mute enabled  
 “0” : Mute disabled

#### ML[4:0] **Master Output (Left Channel) Volume Control**

These five bits select the level of attenuation applied to the Left channel of the Stereo Output signal. The level of attenuation is programmable from 0dB to -46.5dB in 1.5dB increments, providing a total of 32 programmable levels. Please refer to **Table 17** on page 16 for details.

#### MR[4:0] **Master Output (Right Channel) Volume Control**

These five bits select the level of attenuation applied to the Right channel of the Stereo Output signal. The level of attenuation is programmable from 0dB to -46.5dB in 1.5dB increments, providing a total of 32 programmable levels. Please refer to **Table 17** on page 16 for details.

### Alternate Line Output Control Register (Index 04h)

D15	D14	D13	D12	D11	D10	D9	D8	D7	D6	D5	D4	D3	D2	D1	D0	Default
Mute	–	–	ML4	ML3	ML2	ML1	ML0	–	–	–	MR4	MR3	MR2	MR1	MR0	8000h

#### Mute **Stereo Output Mute Control**

“1” : Mute enabled  
 “0” : Mute disabled

#### ML[4:0] **Alternate Line Output (Left Channel) Volume Control**

These six bits select the level of attenuation applied to the Left channel of the Stereo Output signal. The level of attenuation is programmable from 0dB to -46.5dB in 1.5dB increments, providing a total of 32 programmable levels. Please refer to **Table 17** on page 16 for details.

#### MR[4:0] **Alternate Line Output (Right Channel) Volume Control**

These five bits select the level of attenuation applied to the Right channel of the Stereo Output signal. The level of attenuation is programmable from 0dB to -46.5dB in 1.5dB increments, providing a total of 32 programmable levels. Please refer to **Table 17** on page 16 for details.

**Mono Output Control Register (Index 06h)**

D15	D14	D13	D12	D11	D10	D9	D8	D7	D6	D5	D4	D3	D2	D1	D0	Default
Mute	-	-	-	-	-	-	-	-	-	-	MM4	MM3	MM2	MM1	MM0	8000h

**Mute Mono Output Mute Control**

“1” : Mute enabled

“0” : Mute disabled

**MM[4:0] Mono Output Volume Control**

These five bits select the level of attenuation applied to the Mono Output signal. The level of attenuation is programmable from 0dB to -46.5dB in 1.5dB increments, providing a total of 32 programmable levels. Please refer to **Table 17** on page 16 for details.

**Table 17. Stereo and Mono Output Attenuation**

	M4	M3	M2	M1	M0	Level (dB)
0	0	0	0	0	0	0.0
1	0	0	0	0	1	-1.5
2	0	0	0	1	0	-3.0
3	0	0	0	1	1	-4.5
4	0	0	1	0	0	-6.0
5	0	0	1	0	1	-7.5
..	..	..	..	..	..	..
..	..	..	..	..	..	..
28	1	1	1	0	0	-42.0
29	1	1	1	0	1	-43.5
30	1	1	1	1	0	-45.0
31	1	1	1	1	1	-46.5

**PC Beep Input Volume Control Register (Index 0Ah)**

D15	D14	D13	D12	D11	D10	D9	D8	D7	D6	D5	D4	D3	D2	D1	D0	Default
Mute	-	-	-	-	-	-	-	-	-	-	PV3	PV2	PV1	PV0	-	8000h

**Mute PC Beep Input Mute Control**

“1” : Mute enabled

“0” : Mute disabled

**PV[3:0] PC Beep Input Volume Control**

These four bits select the level of attenuation applied to the PC beep input signal. The level of attenuation is programmable from 0dB to -45dB in 3dB increments, providing a total of 16 programmable levels. The beep gain is set at 0dB when PV[3:0] = 0h. Even though the default of the input volume control is mute, as long as RESET# is active, PC Beep will be passively routed to the line outputs.



**Phone Input Volume Control Register (Index 0Ch)**

D15	D14	D13	D12	D11	D10	D9	D8	D7	D6	D5	D4	D3	D2	D1	D0	Default
Mute	-	-	-	-	-	-	-	-	-	-	GN4	GN3	GN2	GN1	GN0	8008h

**Mute Phone Input Mute Control**

“1” : Mute enabled  
 “0” : Mute disabled

**GN[4:0] Phone Input Volume Control**

These five bits select the gain applied to the Phone Input signal. The gain is programmable from -34.5dB to 12dB in 1.5dB increments, providing a total of 32 programmable levels. Please refer to **Table 18** on page 20 for details.

**Mic Input Volume Control Register (Index 0Eh)**

D15	D14	D13	D12	D11	D10	D9	D8	D7	D6	D5	D4	D3	D2	D1	D0	Default
Mute	-	-	-	-	-	-	-	-	20dB	-	GN4	GN3	GN2	GN1	GN0	8008h

**Mute Mic Input Mute Control**

“1” : Mute enabled  
 “0” : Mute disabled

**20dB Mic Boost Control**

“1” : Fixed 20dB gain enabled  
 “0” : Fixed 20dB gain disabled

**GN[4:0] Mic Input Volume Control**

These five bits select the gain applied to the Mic Input signal. The gain is programmable from -34.5dB to 12dB in 1.5dB increments, providing a total of 32 programmable levels. Please refer to **Table 18** on page 20 for details.

**Line Input Control Register (Index 10h)**

D15	D14	D13	D12	D11	D10	D9	D8	D7	D6	D5	D4	D3	D2	D1	D0	Default
Mute	-	-	GL4	GL3	GL2	GL1	GL0	-	-	-	GR4	GR3	GR2	GR1	GR0	8808h

**Mute Line Input Mute Control**

“1” : Mute enabled  
 “0” : Mute disabled

**GL[4:0] Left Channel Gain Control**

These five bits select the gain applied to the LEFT channel of the Line Input signal. The gain is programmable from -34.5dB to 12dB in 1.5dB increments, providing a total of 32 programmable levels. Please refer to **Table 18** on page 20 for details.

**GR[4:0] Right Channel Gain Control**

These five bits select the gain applied to the RIGHT channel of the Line Input signal. The gain is programmable from -34.5dB to 12dB in 1.5dB increments, providing a total of 32 programmable levels. Please refer to **Table 18** on page 20 for details.

**CD Input Control Register (Index 12h)**

D15	D14	D13	D12	D11	D10	D9	D8	D7	D6	D5	D4	D3	D2	D1	D0	Default
Mute	–	–	GL4	GL3	GL2	GL1	GL0	–	–	–	GR4	GR3	GR2	GR1	GR0	8808h

**Mute**                      **CD Input Mute Control**

“1” : Mute enabled

“0” : Mute disabled

**GL[4:0]**                    **Left Channel Gain Control**

These five bits select the gain applied to the LEFT channel of the CD Input signal. The gain is programmable from -34.5dB to 12dB in 1.5dB increments, providing a total of 32 programmable levels. Please refer to **Table 18** on page 20 for details.

**GR[4:0]**                    **Right Channel Gain Control**

These five bits select the gain applied to the RIGHT channel of the CD Input signal. The gain is programmable from -34.5dB to 12dB in 1.5dB increments, providing a total of 32 programmable levels. Please refer to **Table 18** on page 20 for details.

**Video Input Control Register (Index 14h)**

D15	D14	D13	D12	D11	D10	D9	D8	D7	D6	D5	D4	D3	D2	D1	D0	Default
Mute	–	–	GL4	GL3	GL2	GL1	GL0	–	–	–	GR4	GR3	GR2	GR1	GR0	8808h

**Mute**                      **Video Input Mute Control**

“1” : Mute enabled

“0” : Mute disabled

**GL[4:0]**                    **Left Channel Gain Control**

These five bits select the gain applied to the LEFT channel of the Video Input signal. The gain is programmable from -34.5dB to 12dB in 1.5dB increments, providing a total of 32 programmable levels. Please refer to **Table 18** on page 20 for details.

**GR[4:0]**                    **Right Channel Gain Control**

These five bits select the gain applied to the RIGHT channel of the Video Input signal. The gain is programmable from -34.5dB to 12dB in 1.5dB increments, providing a total of 32 programmable levels. Please refer to **Table 18** on page 20 for details.

**Auxiliary Input Control Register (Index 16h)**

D15	D14	D13	D12	D11	D10	D9	D8	D7	D6	D5	D4	D3	D2	D1	D0	Default
Mute	–	–	GL4	GL3	GL2	GL1	GL0	–	–	–	GR4	GR3	GR2	GR1	GR0	8808h

**Mute Auxiliary Input Mute Control**

“1” : Mute enabled

“0” : Mute disabled

**GL[4:0] Left Channel Gain Control**

These five bits select the gain applied to the LEFT channel of the Auxiliary Input signal. The gain is programmable from -34.5dB to 12dB in 1.5dB increments, providing a total of 32 programmable levels. Please refer to **Table 18** on page 20 for details.

**GR[4:0] Right Channel Gain Control**

These five bits select the gain applied to the RIGHT channel of the Auxiliary Input signal. The gain is programmable from -34.5dB to 12dB in 1.5dB increments, providing a total of 32 programmable levels. Please refer to **Table 18** on page 20 for details.

**PCM Output Control Register (Index 18h)**

D15	D14	D13	D12	D11	D10	D9	D8	D7	D6	D5	D4	D3	D2	D1	D0	Default
Mute	–	–	GL4	GL3	GL2	GL1	GL0	–	–	–	GR4	GR3	GR2	GR1	GR0	8808h

**Mute PCM Output Mute Control**

“1” : Mute enabled

“0” : Mute disabled

**GL[4:0] Left Channel Gain Control**

These five bits select the gain applied to the LEFT channel of the PCM Output signal. The gain is programmable from -34.5dB to 12dB in 1.5dB increments, providing a total of 32 programmable levels. Please refer to **Table 18** on page 20 for details.

**GR[4:0] Right Channel Gain Control**

These five bits select the gain applied to the RIGHT channel of the PCM Output signal. The gain is programmable from -34.5dB to 12dB in 1.5dB increments, providing a total of 32 programmable levels. Please refer to **Table 18** on page 20 for details.

Table 18. Programmable Mixer Input Gain Levels

	G4	G3	G2	G1	G0	Level (dB)
0	0	0	0	0	0	12.0
1	0	0	0	0	1	10.5
2	0	0	0	1	0	9.0
3	0	0	0	1	1	7.5
4	0	0	1	0	0	6.0
5	0	0	1	0	1	4.5
6	0	0	1	1	0	3.0
7	0	0	1	1	1	1.5
8	0	1	0	0	0	0.0
9	0	1	0	0	1	-1.5
10	0	1	0	1	0	-3.0
11	0	1	0	1	1	-4.5
12	0	1	1	0	0	-6.0
13	0	1	1	0	1	-7.5
14	0	1	1	1	0	-9.0
15	0	1	1	1	1	-10.5
16	1	0	0	0	0	-12.0
17	1	0	0	0	1	-13.5
18	1	0	0	1	0	-15.0
19	1	0	0	1	1	-16.5
20	1	0	1	0	0	-18.0
21	1	0	1	0	1	-19.5
22	1	0	1	1	0	-21.0
23	1	0	1	1	1	-22.5
24	1	1	0	0	0	-24.0
25	1	1	0	0	1	-25.5
26	1	1	0	1	0	-27.0
27	1	1	0	1	1	-28.5
28	1	1	1	0	0	-30.0
29	1	1	1	0	1	-31.5
30	1	1	1	1	0	-33.0
31	1	1	1	1	1	-34.5

**Record Select Register (Index 1Ah)**

D15	D14	D13	D12	D11	D10	D9	D8	D7	D6	D5	D4	D3	D2	D1	D0	Default
-	-	-	-	-	SL2	SL1	SL0	-	-	-	-	-	SR2	SR1	SR0	0000h

**SL[2:0]**

**Record Source Select (Left Channel)**

These bits determine the record source for the left channel.

SL2	SL1	SL0	Left Record Source
0	0	0	Mic
0	0	1	CD (L)
0	1	0	Video In (L)
0	1	1	Aux In (L)
1	0	0	Line In (L)
1	0	1	Stereo Mix (L)
1	1	0	Mono Mix
1	1	1	Phone

**SR[2:0] Record Source Select (Right Channel)**

These bits determine the record source for the right channel.

SR2	SR1	SR0	Right Record Source
0	0	0	Mic
0	0	1	CD (R)
0	1	0	Video In (R)
0	1	1	Aux In (R)
1	0	0	Line In (R)
1	0	1	Stereo Mix (R)
1	1	0	Mono Mix
1	1	1	Phone

**Record Gain Control Register (Index 1Ch)**

D15	D14	D13	D12	D11	D10	D9	D8	D7	D6	D5	D4	D3	D2	D1	D0	Default
Mute	–	–	–	GL3	GL2	GL1	GL0	–	–	–	–	GR3	GR2	GR1	GR0	8000h

**Mute Record Mute Control**

“1” : Mute enabled  
 “0” : Mute disabled

**GL[3:0] Record Gain Control (Left Channel)**

These four bits select the gain applied to the LEFT channel recording source. The gain is programmable from 0dB to 22.5dB in 1.5dB increments, providing a total of 16 programmable levels. The gain is set at 0dB when GL[3:0] = 0h.

**GR[3:0] Record Gain Control (Right Channel)**

These four bits select the gain applied to the RIGHT channel recording source. The gain is programmable from 0dB to 22.5dB in 1.5dB increments, providing a total of 16 programmable levels. The gain is set at 0dB when GR[3:0] = 0h.

**General Purpose Register (Index 20h)**

D15	D14	D13	D12	D11	D10	D9	D8	D7	D6	D5	D4	D3	D2	D1	D0	Default
–	–	3D	–	–	–	MIX	MS	LPBK	–	–	–	–	–	–	–	0000h

**3D 3D Stereo Enhancement**

“1” : Enable 3D  
 “0” : Disable 3D

**MIX Mono Output Mode**

“1” : Mic Output  
 “0” : Mono mix output

**MS Microphone Select**

“1” : Microphone 2  
 “0” : Microphone 1

**LPBK Loopback Mode**

“1” : DAC/ADC Loopback enabled  
 “0” : DAC/ADC Loopback disabled

**3D Control Register (Index 22h)**

D15	D14	D13	D12	D11	D10	D9	D8	D7	D6	D5	D4	D3	D2	D1	D0	Default
-	-	-	-	-	-	-	-	-	-	-	-	DP3	DP2	DP1	DP0	0000h

**DP[3:0] 3D Depth Control**

These four bits control the linear depth control of the 3D stereo enhancement built into the codec. The gain is programmable from 0% to 100% in 6.67% increments, providing a total of 16 programmable levels. The default value corresponds to no stereo enhancement.

**Power Down and Status Register (Index 26h)**

D15	D14	D13	D12	D11	D10	D9	D8	D7	D6	D5	D4	D3	D2	D1	D0	Default
EAPD	PR6	PR5	PR4	PR3	PR2	PR1	PR0	-	-	-	-	REF	ANL	DAC	ADC	0000h

**EAPD Enable Amplifier Power Down**

“1” : Powerdown External Power Amplifier

“0” : External Power Amplifier active

The signal polarity at pin 47, EAPD is identical to bit description.

**PR[5:0] Power Down Mode Bits**

These read/write bits are used to control the power down states of the ICE1232. Each power down function bit is enabled by setting the respective bit high. The power down modes controlled by each bit is described in the table below:

Bit	Function
PR0	ADC and Mux Powerdown
PR1	DAC Powerdown
PR2	Mixer Powerdown (VREF on)
PR3	Mixer Powerdown (VREF off)
PR4	AC Link Powerdown (BIT_CLK off)
PR5	Internal Clock Disabled
PR6	Alternate Line Out Powerdown

**Status (READ Only) bits**

These bits are used to monitor the readiness of some sections of the ICE1232. Reading a “1” from any of these bits would be an indication of a “ready” state.

Bit	Status Bit
REF	VREF at nominal level
ANL	Mixer, Mux and Volume Controls ready
DAC	DAC ready to accept data
ADC	ADC ready to transmit data

**Extended Audio ID Register (Index 28h)**

D15	D14	D13	D12	D11	D10	D9	D8	D7	D6	D5	D4	D3	D2	D1	D0	Default
ID1	ID0	-	-	-	-	AMAP	-	-	-	-	-	-	-	-	VRA	0201h

The Extended Audio ID is a read only register.

**ID[1:0] (See Table below)**

One primary and a maximum of three secondary codecs may be supported as an option.

**Table 19. Multiple Codec Mode Status Bits**

ID1	ID0	Codec Mode
0	0	Primary Codec (default)
0	1	Secondary Codec 1
1	0	Secondary Codec 2
1	1	Secondary Codec 3

**Note:** The state of the ID pins is reported in reverse polarity on register 28h, bits D15 and D14. If you use Table 16 to configure the codec via pins 45 and 46, use the inverse values. Please, refer to **Figure 11** on page 25. Digital Controllers may support up to four DATA\_IN pins to support one primary and three secondary codecs. BIT\_CLK is an output for the primary codec and an input pin for the controller and secondary codecs. ID[1:0] pins with internal pull-up resistors defaults codec as primary codec.

**AMAP**                      **Slot/DAC mapping based on Codec ID**  
 “1” : Feature implemented in compliance to AC ‘97 2.1 Appendix D

**VRA**                         **Variable Sampling Rate PCM Audio**  
 “1” : Feature implemented in compliance to AC ‘97 2.1 Appendix A

**Extended Audio Status/Control Register(Index 2Ah)**

D15	D14	D13	D12	D11	D10	D9	D8	D7	D6	D5	D4	D3	D2	D1	D0	Default
–	–	–	–	–	–	–	–	–	–	–	–	–	–	–	VRA	0000h

**VRA**                         **Variable Sampling Rate Mode control**  
 “1” : Enable VSR  
 “0” : Fixed 48kHz sampling rate

**PCM DAC Sample Rate Register (Index 2Ch)**

D15	D14	D13	D12	D11	D10	D9	D8	D7	D6	D5	D4	D3	D2	D1	D0	Default
SR15	SR14	SR13	SR12	SR11	SR10	SR9	SR8	SR7	SR6	SR5	SR4	SR3	SR2	SR1	SR0	BB80h

**SR[15:0]**                    **DAC Sample Rate (in Hz)**  
 16-bit unsigned value representing the sample rate in 1Hz resolution. The default value is 48kHz (48000 = BB80h).

**PCM ADC Sample Rate Register (Index 32h)**

D15	D14	D13	D12	D11	D10	D9	D8	D7	D6	D5	D4	D3	D2	D1	D0	Default
SR15	SR14	SR13	SR12	SR11	SR10	SR9	SR8	SR7	SR6	SR5	SR4	SR3	SR2	SR1	SR0	BB80h

**SR[15:0]**                    **ADC Sample Rate (in Hz)**  
 16-bit unsigned value representing the sample rate in 1Hz resolution. The default value is 48kHz (48000 = BB80h).

**Vendor Reserved Register (Index 5Ah)**

D15	D14	D13	D12	D11	D10	D9	D8	D7	D6	D5	D4	D3	D2	D1	D0	Default
-	-	-	-	-	-	-	-	Res.	Res.	Res.	Res.	IB1	IB0	-	Res.	0021h

**Res. Reserved**  
 These read/write bits are used for testing the digital modes of the audio codec. Do not access them during Normal operation.

**IB[1:0] Analog Current Setting Bits**  
 Normally these bits should be left at default when analog operating at 5V supply. The four possible settings adjust the power consumption of the analog section. The power-up default 00b sets the codec for the best analog performance at 5V. At 3.3V analog supply, 10b should be set for the best analog performance instead of default 00b. Setting to 11b puts the codec in its most aggressive low power consumption mode during normal operation. This mode is desirable for system designs with limited power budget such as battery operated portable devices. Intermediate steps 01b and 10b set the analog bias current to 40% and 50% of maximum respectively. However it does not translate linearly to the total analog power consumption current.

**Vendor Identification Register (Index 7Ch)**

D15	D14	D13	D12	D11	D10	D9	D8	D7	D6	D5	D4	D3	D2	D1	D0	Default
F7	F6	F5	F4	F3	F2	F1	F0	S7	S6	S5	S4	S3	S2	S1	S0	4943h

The upper and lower byte of this register (index 7Ch), in conjunction with the upper byte of index register 7Eh, make up the vendor identification code for the ICE1232. The Vendor ID Code (in ASCII format) is equal to ICE, where:

**F[7:0] Upper Byte (Index 7Ch) D[15:8] = I**

**S[7:0] Lower Byte (Index 7Ch) D[7:0] = C**

**T[15:8] Upper Byte (Index 7Eh) D[15:8] = E**

**Revision Identification Register (Index 7Eh)**

D15	D14	D13	D12	D11	D10	D9	D8	D7	D6	D5	D4	D3	D2	D1	D0	Default
T7	T6	T5	T4	T3	T2	T1	T0	REV7	REV6	REV5	REV4	REV3	REV2	REV1	REV0	4511h

The upper byte of this register is used in conjunction with index register 7Ch to make up the Vendor ID code for the ICE1232. The lower byte identifies ICE1232 and its revision code.

**T[15:8] See description in Vendor Identification Register.**

**REV[7:0] Revision ID**  
 “11”: Revision Number

**Note:** As a reference, other valid IDs associated with ICE AC’97 products are: “01” for ICE1230.



### Multiple Codec Example

One primary codec and three secondary codecs, with tag bits ID[1:0] defining which codec is primary and the order of the secondary codecs. Note that the ID[1:0] pins are internally pulled up; therefore, it is necessary to pull the ID[1:0] pins low to set the codec as secondary. Notice that the state of the ID[1:0] pins are reflected in reverse polarity as shown on **Table 19** on page 23.

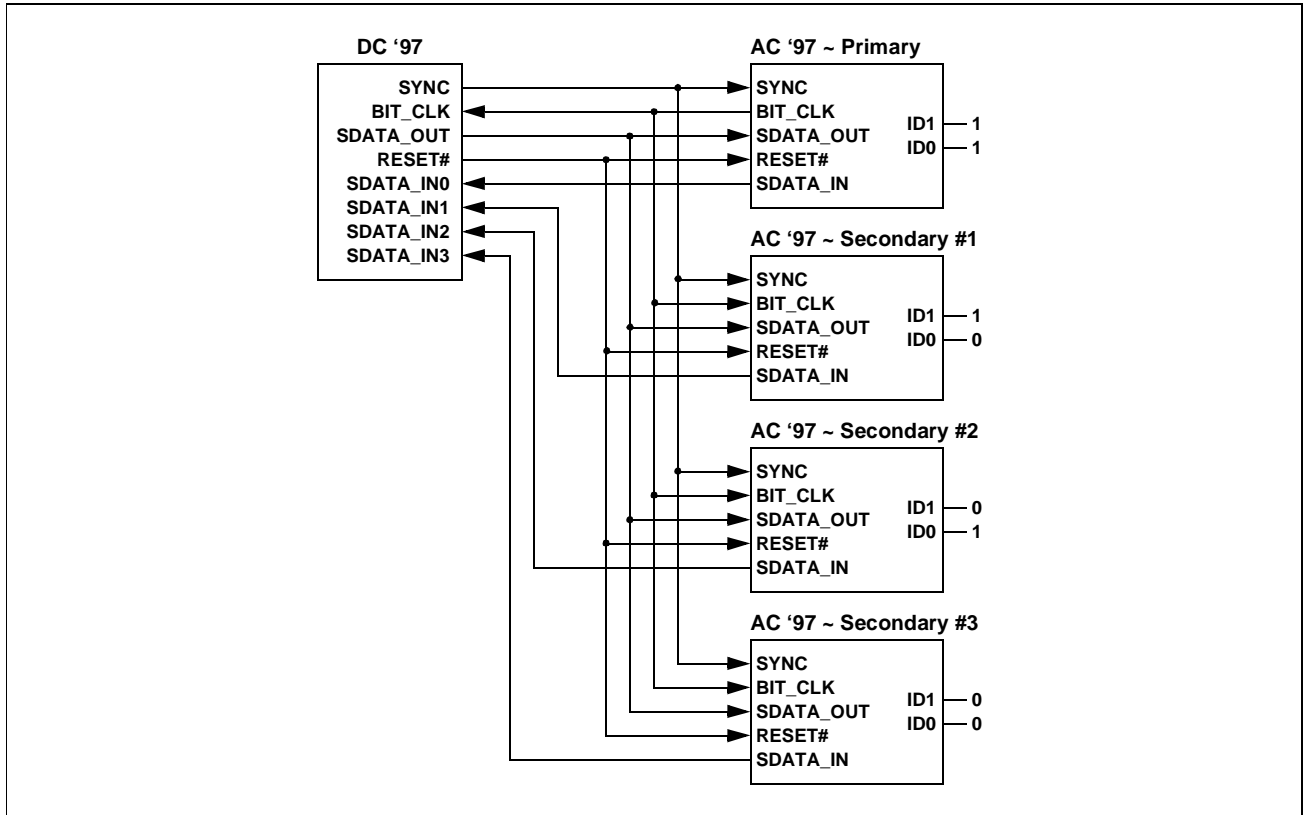

Figure 11. Multiple Codec Example

### Power Management

The ICE1232 may be placed in several power down states using the power down control bits located in index register 26h. **Table 20** lists the power down states accessible through this register.

**Table 20. Power Down Mode Bits**

Bit	Function
PR0	ADC and Mux Powerdown
PR1	DAC Powerdown
PR2	Mixer Powerdown (VREF on)
PR3	Mixer Powerdown (VREF off)
PR4	AC Link Powerdown (BIT_CLK off)
PR5	Internal Clock Disabled
PR6	Alternate Line Out Powerdown

**Note:** Registers maintain values in sleep mode (PR4 write) and wake up with a warm reset (register values) or a cold reset (default values). Power Down and Status register (index 26h) read action verifies stability before power down write action occurs.

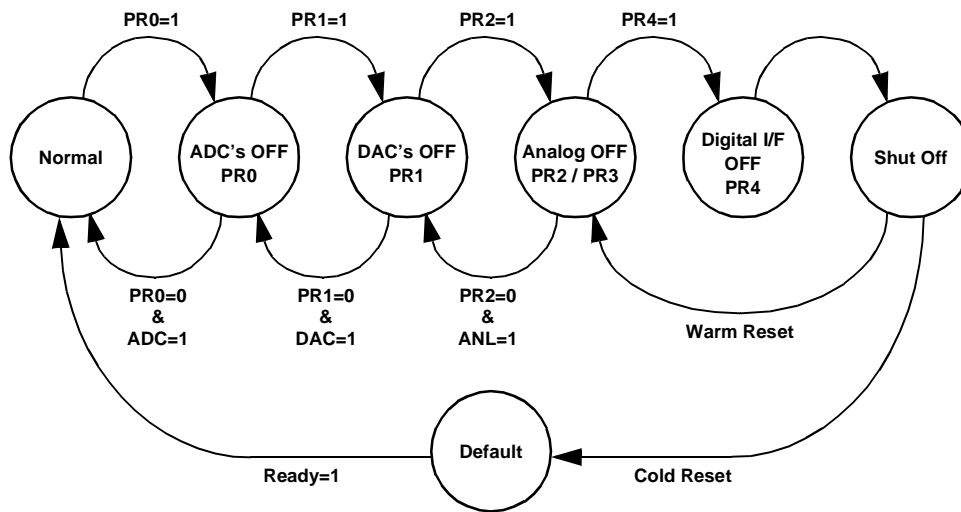

Note: In this example, the Analog Mixer has been disabled, but VREF is still on.

**Figure 12. AC'97 Power Down / Power Up Procedure**

Complete power down of the AC '97 device is achieved by sequential writes to the Power Down and Status Control Register (Index 26h) as follows:

- |                      |                 |
|----------------------|-----------------|
| Normal Operations:   | PR[6:0] = 00h   |
| ADC's and Input Mux: | PR0 = 1 (write) |
| DAC's:               | PR1 = 1 (write) |
| Analog Mixer:        | PR2 = 1 (write) |
| VREFOUT:             | PR3 = 1 (write) |
| AC-link:             | PR4 = 1 (write) |
| Internal Clocks:     | PR5 = 1 (write) |
| Alt. Line Out:       | PR6 = 1 (write) |

## Power Management (*continued...*)

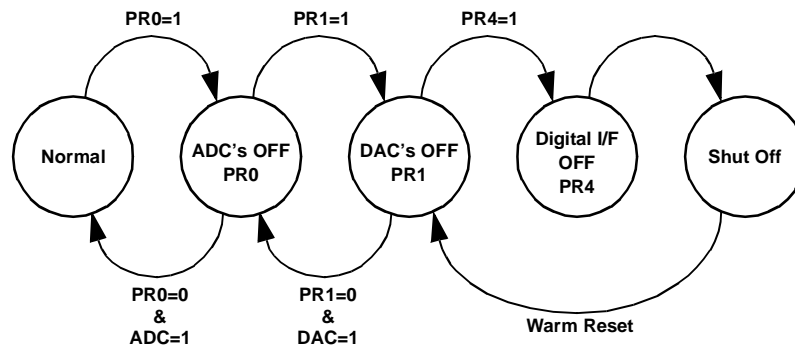

Note: To power up the codec, a warm reset is required; PR4 is reset to zero upon either reset.

**Figure 13. AC'97 Power Down Procedure with Analog Section Still Active**

## Test Mode Operation

### ATE Test Mode: (PCB in-circuit Testing of the ICE1232)

ATE Test mode is entered when the SDATA\_OUT signal is sampled at the rising edge of the RESET# signal. In this mode, the SDATA\_IN and BIT\_CLK pins are placed in a high impedance (Hi-Z) state. This mode of operation doesn't occur under normal operating conditions.

### Vendor Test Mode:

Vendor Test mode is entered when the SYNC signal is sampled during the rising edge of the RESET# signal. This mode of operation doesn't occur under normal operating conditions.

Package Dimensions

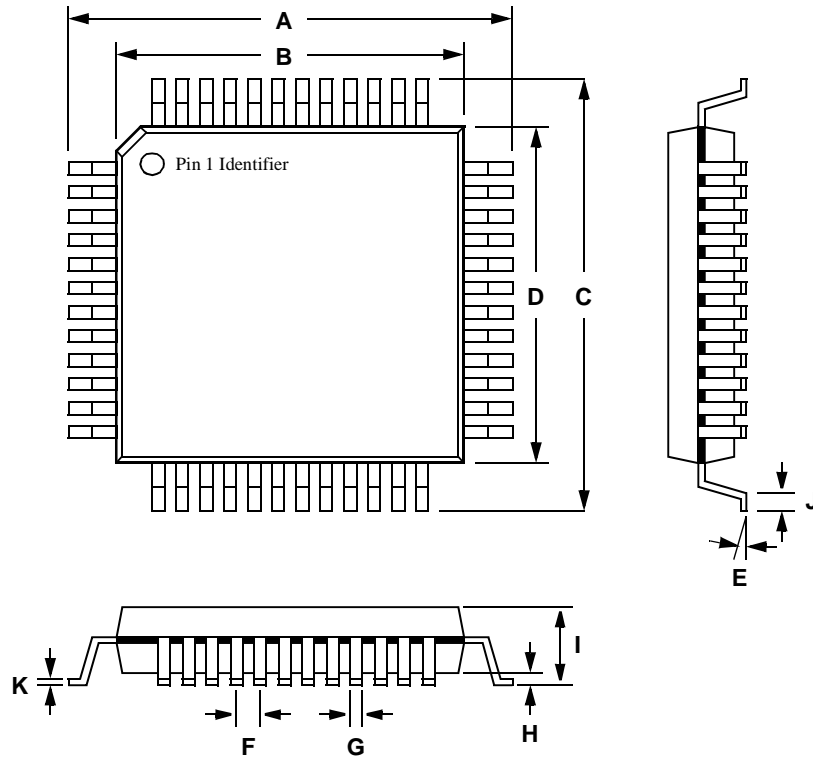

Mechanical Dimensions (millimeters, unless otherwise stated)

Symbol	A	B	C	D	E	F	G	H	I	J	K
<b>48-pin (7x7) TQFP</b>											
minimum	8.6	6.9	8.6	6.9	0°	0.5	0.17	0.05	1.0	0.45	0.100
maximum	9.4	7.1	9.4	7.1	10°		0.27	0.15		0.75	0.175
<b>48-pin (7x7) LQFP</b>											
minimum	8.6	6.9	8.6	6.9	0°	0.5	0.13	0.05	–	0.3	0.100
maximum	9.4	7.1	9.4	7.1	10°		0.28	0.15	1.7	0.7	0.175